



Contents

Mag-Drive Series Description.....	3
D Series Model Number System.....	4
P Series Model Number System.....	5
T Series Model Number System.....	6
D Series Pump Mounting Dimensions.....	7
P Series Pump Mounting Dimensions.....	7
T Series Pump Mounting Dimensions.....	8
D Series Pump Performance Data.....	9
P Series Pump Performance Data.....	9
T Series Pump Performance Data.....	9
Temperature Limits.....	10
Temperature Effect on Magnet Torque.....	10
D Series Pump Materials of Construction.....	11
P Series Pump Materials of Construction.....	12
T Series Pump Materials of Construction.....	13
D Series Pump NPIPr Data (PSIa).....	14
P Pump NPIPr Data (PSIa).....	14
T Pump NPIPr Data (PSIa).....	14

Mag-Drive Series Description

Tuthill Pump Group has been a leader in the development and manufacture of positive displacement pumps since 1927. D, T, & P Series Pumps have been at the forefront in the development of miniature magnetically coupled gear pumps since 1977. From this vast knowledge in both magnet and pump technology have come the D, P, and T series of magnetically coupled sealless pumps. The D, P, and T series of pumps combines the time proven reliability of external gear design with the advantages of magnetically coupled sealless construction. These pumps incorporate a wide variety of magnet options including Ceramic (Strontium Ferrite) and Samarium Cobalt magnets for a broader temperature range. They are designed for hazardous or toxic pumping applications where fluid leakage cannot be tolerated, incorporating full encapsulation to protect the inner magnet.

D series pumps have capacities to 121 gph (459 LPH) and differential pressures up to 250 psi 17.2 bar. with a maximum system pressure rating up to 500 psi 34.5 bar without speed reduction. The D series Ceramic magnets are rated up to 50 in-oz. of torque. The D series Samarium Cobalt magnets are rated to 240 in-oz. of torque. This series is designed to be adapter mounted for direct coupling to a wide variety of motor offerings.

P series pumps have capacities to 63 gph (238 LPH) and differential pressures up to 130 psi with a maximum system pressure rating up to 300 psi 20.7 bar without speed reduction. The P series Ceramic magnets are rated up to 50 in-oz. of torque. This series is designed to be adapter mounted for direct coupling to a wide variety of motor offerings.

T series pumps have capacities to 650 gph (2460 LPH) and differential pressures up to 250 psi with a maximum system pressure rating up to 500 psi 34.5 bar without speed reduction. The T series Samarium Cobalt magnets are rated up to 460 in-oz. of torque. This series is designed to be adapter mounted for direct coupling to a wide variety of motor offerings.

WARNING

The magnets in magnetically coupled pumps create very strong magnetic fields. Special care must be taken with the following:

- Pacemakers - Magnets can upset the timing of pacemakers. These magnets should be kept away from all pacemakers. Because of the health risks involved the importance of this cannot be overstated.
- Credit Cards - Magnets can scramble the information on a credit card's magnetic tape.
- Computers, Computer Tapes and Computer Disks - Magnets can scramble the information on the memory device.
- Watches - Magnets can affect the workings of traditional mechanical spring driven watches as well as chip and electronically controlled designs.
- Electronic Instruments - Sensitive electronic instruments and devices may change calibration or be damaged by a powerful magnetic field.
- Explosive Atmosphere - Rare earth magnets and magnetic materials may create sparks through contact in handling. Never handle rare earth magnets in explosive atmospheres because sparking may ignite the atmosphere.
- Do not place hand or fingers between the housing and adapter. The magnets are extremely strong and will attract all metallic objects and can be the source of pinch points. Do not wear watches or other metallic jewelry when working with magnets.

D Series Model Number System

Positions	Series	Magnet Torque	Material of Construction	Displacement mL/rev			Gear and Bearing Material			O-Ring	Port Size	Magnet	Bypass	Motor and Drive		Open	Operating Temperature	Open
	D	G	S	.	6	8	P	P	P	T	1	N	M	9	7	0	0	0
1	2	3	4	5	6	7	8	9	10	11	12	13	14	15	16	17	18	

Pos. 1 - Pump Series

D = 1.67" Diameter Metal Pump

Pos. 2 - Magnet Torque

B = 30 oz/in

Not available for 1.2, 1.3, 1.6, 2.0, or 2.3

G = 65 oz/in

X = 240 oz/in

Pos. 3 - Wetted Material of Construction

S = 316 Stainless Steel

H = Hastelloy C276

T = Titanium

Pos. 4-6 - Pump Size; ml/rev.

.11 = nominal 6 GPH@3500 RPM

.19 = nominal 10 GPH@3500 RPM

.23 = nominal 12 GPH@3500 RPM

.38 = nominal 20 GPH@3500 RPM

.57 = nominal 30 GPH@3500 RPM

.68 = nominal 36 GPH@3500 RPM

.80 = nominal 42 GPH@3500 RPM

.99 = nominal 52 GPH@3500 RPM

1.2 = nominal 63 GPH@3500 RPM

1.3 = nominal 68 GPH@3500 RPM

1.6 = nominal 84 GPH@3500 RPM

2.0 = nominal 105 GPH@3500 RPM

2.3 = nominal 121 GPH@3500 RPM

Pos. 7 - 9 - Gear and Bearing Material

PPP = PPS (Polyphenylene Sulfide)

EEE = PEEK (Polyetheretherketone)

TTT = PTFE

Available in .23, .38, .57, .68, .80, 1.2, and 1.6
only Requires PTFE O-rings and welded magnet
Max Differential Pressure = 100PSI

Pos. 10 - O-Ring

V= Viton

T = PTFE

E = EPR

Pos. 11 - Port Size

1 = 1/8" NPT.

Not available for .99, 1.2, 1.3, 1.6, 2.0, or 2.3 sizes. Not available in Hastelloy or Titanium

2 = 1/4" NPT

Pos. 12 - Magnet

N = PPS or PEEK Encapsulated

Material based on pos. 7-9

W = Welded

Required for PTFE gears, Hastelloy, Titanium pumps. Welded not available in B size magnet

Pos. 13 - Bypass

N = None

M = Medium (Standard) 60 PSI

L = Low Pressure 30 PSI

Low Pressure not available in .99 - 2.3 sizes

H = High Pressure 130 PSI

High Pressure not available in .99 - 2.3 sizes

Bypass is not available in Hastelloy or Titanium

Pos 14 - 15 - Motor and Drive

See Motor and Drive Price Sheets for Options

00 = Pump Only

Pos 16. - Open

0 = Open

Pos. 17 - Operating Temperatures

PTFE - 140 °F (60 °C)

PPS - (Polyphenylene Sulfide) 250 °F (121 °C)

PEEK - (Polyetheretherketone) 350 °F (176 °C)

Note: Temperatures greater than 140 °F (60 °C) may reduce flow/pressure. Approximate Gear & Bearing Maximum Temperature Limits

Pos. 18 - Open

0 = Open

Service Pack Option

Add "SP" in front of the model number, followed by positions 1-10, 16,17, & 18 of pump model

Note: SPDB, SPDG, & SPDX default to SPDD (Example- SPDDS1.2PPPT000)

Service Pack Contains:

- Gears
- Bearings
- O-Rings
- Lubricant
- Instruction Sheet

P Series Model Number System

Positions	Series	Magnet Torque	Material of Construction	Displacement mL/rev			Gear and Bearing Material			O-Ring	Port Size	Magnet	Bypass	Motor and Drive		Open	Open	Open
	P	G	S	.	5	7	P	P	P	V	1	N	N	1	5	0	0	0
1	2	3	4	5	6	7	8	9	10	11	12	13	14	15	16	17	18	

Pos. 1 - Pump Series

P = Plastic Injection Molded

Pos. 2 - Magnet Torque

B = 30 oz/in

Not available for 1.2 size

G = 65 oz/in

Pos. 3 - Wetted Material of Construction

S = 316 Stainless Steel

H = Hastelloy C276

T = Titanium

Pos. 4-6 - Pump Size; ml/rev.

.38 = nominal 20 GPH@3500 RPM

.57 = nominal 30 GPH@3500 RPM

.68 = nominal 36 GPH@3500 RPM

1.2 = nominal 63 GPH@3500 RPM

Pos. 7 - 9 - Gear and Bearing Material

PPP = PPS (Polyphenylene Sulfide)

Pos. 10 - O-Ring

V= Viton

E = EPR

Pos. 11 - Port Size

1 = 1/8" NPT

Pos. 12 - Magnet

N = PPS Encapsulated

W = Welded

Required for Hastelloy, Titanium pumps

Welded not available in B size magnet

Pos. 13 - Bypass

N = None

M = Medium (Standard) 60 PSI

L = Low Pressure 30 PSI

Low Pressure not available in 1.2 size

Bypass is not available in Hastelloy or Titanium

Pos 14 & 15 - Motor and Drive

See Motor and Drive options

00 = Pump Only

Pos 16. - Open

0 = Open

Pos. 17 - Open

0 = Open

Pos. 18 - Open

0 = Open

Service Pack Option

Not Available

T Series Model Number System

Positions	Series	Magnet Torque	Material of Construction	Displacement mL/rev			Gear and Bearing Material			O-Ring	Port Size	Magnet	Bypass	Motor and Drive		Open	Operating Temperature	Open
	T	X	S	5	.	3	P	P	P	T	3	N	N	A	2	0	0	0
1	2	3	4	5	6	7	8	9	10	11	12	13	14	15	16	17	18	

Pos. 1 - Pump Series

T = 3" Diameter Metal Pump

Pos. 2 - Magnet Torque

X = 240 oz/in.

Required for 2.6, 5.3, and 7.9 sizes

W = 460 oz/in.

Required for 8.0 and 12.0 sizes

Pos. 3 - Wetted Material of Construction

S = 316 Stainless Steel

H = Hastelloy C276

T = Titanium

Pos. 4-6 - Pump Size: ml/rev.

2.6 = nominal 137 GPH@3500 RPM

5.3 = nominal 279 GPH@3500 RPM

7.9 = nominal 416 GPH@3500 RPM

8.0 = nominal 421 GPH@3500 RPM

12. = nominal 650 GPH@3500 RPM

Pos. 7 - 9 - Gear and Bearing Material

PPP = PPS (Polyphenylene Sulfide)

EEE = PEEK (Polyetheretherketone)

Pos. 10 - O-Ring

V= Viton

T = PTFE

E = EPR

Pos. 11 - Port Size

3 = 3/8" NPT

Required for 2.6, 5.3, and 7.9 sizes

7 = 3/4" NPT Suction, 1/2" NPT on Discharge

Required for 8.0 and 12.0 sizes

Pos. 12 - Magnet

N = PPS or PEEK Encapsulated

Material based on pos. 7-9

W = Welded

Required for Hastelloy or Titanium pumps

Not available for Stainless

Pos. 13 - Bypass

N = Not Available

Pos 14 - 15 - Motor and Drive

See Motor and Drive Price Sheets for Options

00 = Pump Only

Pos 16. - Open

0 = Open

Pos. 17 - Operating Temperatures

PPS (Polyphenylene Sulfide) 250°F (121°C)

PEEK (Polyetheretherketone) 350°F (176°C)

Note: Temperatures greater than 140 °F (60 °C) may reduce flow/pressure. Approximate Gear & Bearing Maximum Temperature Limits

Pos. 18 - Open

0 = Open

Service Pack Option

Add "SP" in front of the model number, followed by positions 1-10, 16,17, and 18 of pump model

Service Pack Contains:

- Gears
- Bearings
- O-Rings
- Lubricant
- Instruction Sheet

D Series Pump Mounting Dimensions

Displacement .11 to 2.3

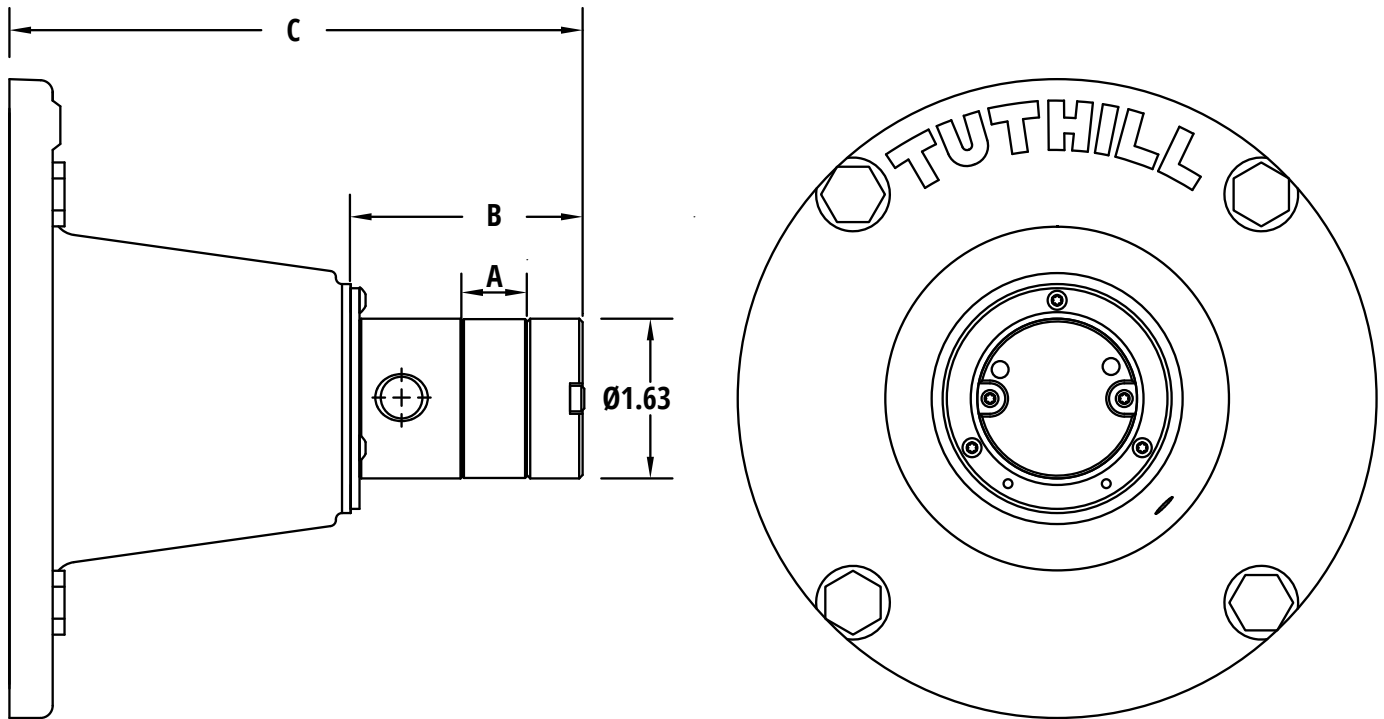

Displacement	Dimension A Inch [mm]	Dimension B Inch [mm]	Dimension C Inch [mm]
.11 & 0.19	0.125 [3.2]	1.83 [46.4]	5.30 [134.6]
.23 & .38	0.250 [6.4]	1.95 [49.5]	5.42 [137.7]
.57	0.375 [9.5]	2.07 [52.7]	5.54 [140.7]
.68 & .80	0.450 [11.4]	2.15 [54.7]	5.62 [142.7]
.99 & 1.2	0.657 [16.7]	2.36 [59.9]	5.83 [148.1]
1.3	0.750 [19.0]	2.45 [62.3]	5.92 [150.4]
1.6 & 2.0	0.900 [22.9]	2.60 [66.0]	6.07 [154.2]
2.3	1.000 [25.4]	2.70 [68.6]	6.17 [156.7]

P Series Pump Mounting Dimensions

Displacement .38 to 1.2

Displacement	Dimension A Inch [mm]	Dimension B Inch [mm]	Dimension C Inch [mm]
.38	0.250 [6.4]	1.95 [49.5]	5.42 [137.7]
.57	0.375 [9.5]	2.07 [52.7]	5.54 [140.7]
.68	0.450 [11.4]	2.15 [54.7]	5.62 [142.7]
1.2	0.657 [16.7]	2.36 [59.9]	5.83 [148.1]

T Series Pump Mounting Dimensions

Displacement 2.6 to 7.9

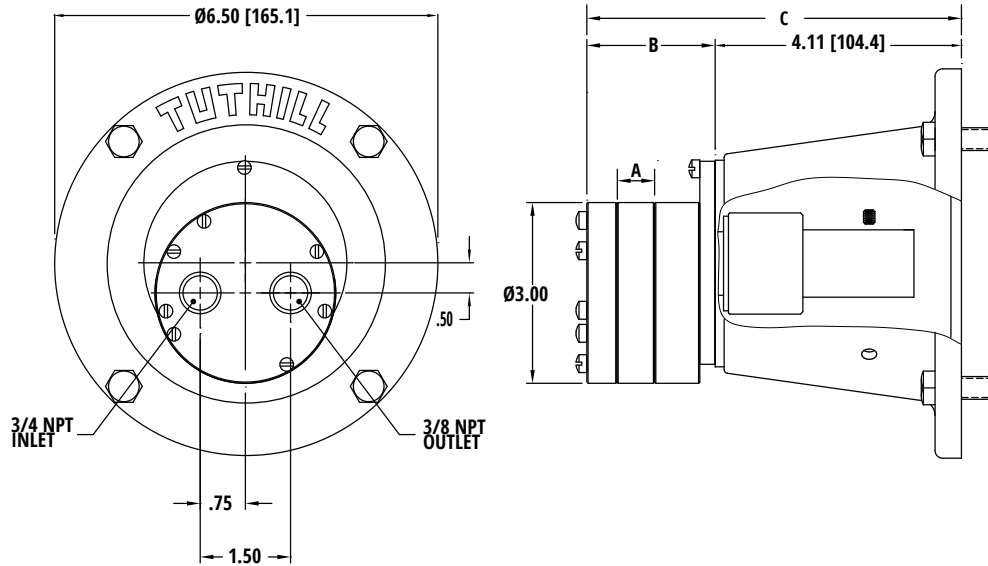

Displacement	Dimension A Inch [mm]	Dimension B Inch [mm]	Dimension C Inch [mm]
2.6	.313 [7.95]	1.82 [46.2]	5.93 [150.6]
5.3	.625 [15.8]	2.12 [53.8]	6.24 [158.5]
7.9	.938 [23.8]	2.43 [61.8]	6.55 [166.4]

Displacements 8.0 to 12.0

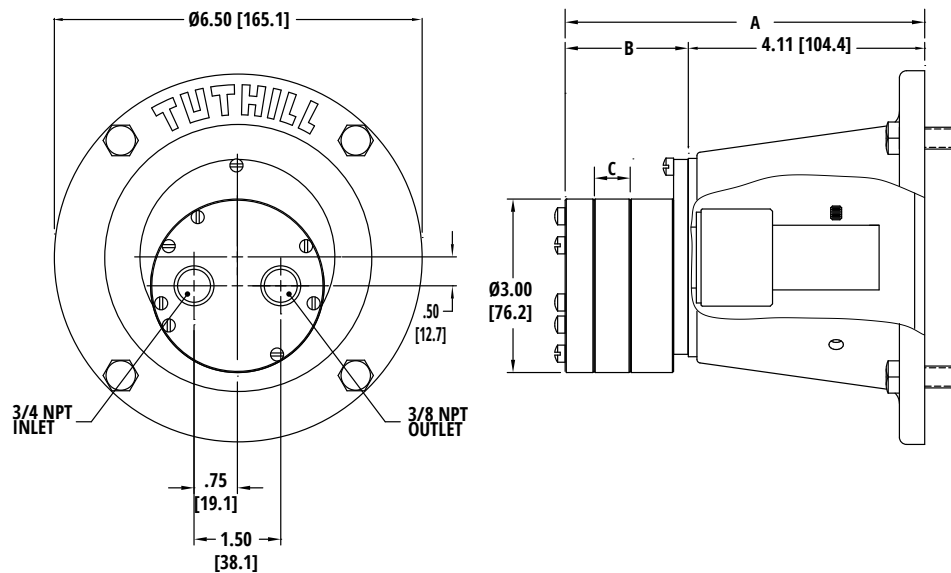

Displacement	Dimension A Inch [mm]	Dimension B Inch [mm]	Dimension C Inch [mm]
TWS 8.0	7.00 [177.8]	2.65 [59.7]	.625 [15.9]
TWS 12.	7.32 [185.9]	2.96 [75.1]	.938 [23.8]

D Series Pump Performance Data

Size (ml/rev)	GPH @ 0 PSI and 3500 RPM	LPH @ 0 PSI and 3500 RPM	Maximum Differential Pressure PSI (bar)
.11	6	22	250 (17.2)
.19	10	38	250 (17.2)
.23	12	46	250 (17.2)
.38	20	76	250 (17.2)
.57	30	114	250 (17.2)
.68	36	136	250 (17.2)
.80	42	160	250 (17.2)
.99	52	198	200 (13.8)
1.2	63	239	200 (13.8)
1.3	69	259	175 (12.1)
1.6	84	319	150 (10.3)
2.0	105	399	150 (10.3)
2.3	121	459	150 (10.3)

Note: Maximum system pressure is 500 psi (34.5 bar) and viscosity range is 0.3 - 2000 cps without speed reduction.

P Series Pump Performance Data

Size (ml/rev)	GPH @ 0 PSI and 3500 RPM	LPH @ 0 PSI and 3500 RPM	Maximum Differential Pressure PSI (bar)
.38	20	76	130 (9)
.57	30	114	110 (7.6)
.68	36	136	90 (6.2)
1.2	63	238	70 (4.8)

Note: Maximum system pressure is 300 psi (20.7 bar) and viscosity range of 0.3 - 1000 cps without speed reduction.

T Series Pump Performance Data

Size (ml/rev)	GPH @ 0 PSI and 3500 RPM	LPH @ 0 PSI and 3500 RPM	Maximum Differential Pressure PSI (bar)
2.6	137	518	250 (17.2)
5.3	279	1056	145 (10)
7.9	416	1575	95 (6.6)
8.0	421	1593	150 (10.3)
12.	650	2460	120 (8.3)

Note: Maximum system pressure is 500 psi (34.5 bar) and viscosity range of 0.3 - 2000 cps without speed reduction.

Temperature Limits

D Series	P Series	T Series
-50 °F (-46 °C) to 350 °F (176 °C)	0 °F (18 °C) to 150 °F (65 °C)	-50 °F (-46 °C) to 350 °F (176 °C)
Gear and Bearing - PPS (Polyphenylene Sulfide) 250 °F (121 °C)	Gear - PPS (Polyphenylene Sulfide) 0 °F (18 °C) to 150 °F (65 °C)	Gear - PPS (Polyphenylene Sulfide) 250 °F (121 °C)
Gear and Bearing - PEEK (Polyetheretherketone) 350 °F (176 °C)	N/A	Gear and Bearing - PEEK (Polyetheretherketone) 350 °F (176 °C)
Gear and Bearing - PTFE 140 °F (60 °C)	N/A	N/A

Temperature Effect on Magnet Torque

Temperature		Torque		Magnet Torque							
°C	°F	Percent		Ounce Inch				Millinewton Meter			
B, G, X, & W		B & G	X & W	B	G	X	W	B	G	X	W
22	72	100%	100%	30	65	240	460	211.8	459.0	1694.8	3248.3
30	86	98%	99%	29.4	63.7	238.1	456.4	207.6	449.8	1681.4	3222.9
40	104	96%	98%	28.7	62.1	235.8	452	202.6	438.5	1665.1	3191.8
50	122	93%	97%	27.9	60.5	233.5	447.5	197.0	427.2	1648.9	3160.0
60	140	91%	96%	27.2	58.8	231.1	443	192.1	415.2	1631.9	3128.3
70	158	88%	95%	26.4	57.2	228.8	438.6	186.4	403.9	1615.7	3097.2
80	176	86%	94%	25.7	55.6	226.5	434.1	181.5	392.6	1599.4	3065.4
90	194	83%	93%	24.9	54	224.2	429.6	175.8	381.3	1583.2	3033.6
100	212	81%	92%	24.2	52.3	221.8	425.2	170.9	369.3	1566.3	3002.6
110	230	78%	91%	23.4	50.7	219.5	420.7	165.2	358.0	1550.0	2970.8
120	248	76%	90%	22.7	49.1	217.2	416.3	160.3	346.7	1533.8	2939.7
130	266	73%	90%	21.9	47.5	214.8	411.8	154.6	335.4	1516.8	2907.9
140	284	71%	89%	21.2	45.8	212.5	407.3	149.7	323.4	1500.6	2876.2
150	302	68%	88%	20.4	44.2	210.2	402.9	144.1	312.1	1484.3	2845.1
160	320	66%	87%	19.7	42.6	207.9	398.4	139.1	300.8	1468.1	2813.3
170	338	63%	86%	18.9	41	205.5	393.9	133.5	289.5	1451.2	2781.6
180	356	61%	85%	18.2	39.3	203.2	389.5	128.5	277.5	1434.9	2750.5
190	374	58%	84%	17.4	37.7	200.9	385	122.9	266.2	1418.7	2718.7
200	392	56%	83%	16.7	36.1	198.6	380.6	117.9	254.9	1402.4	2687.6
210	410	53%	82%	15.9	34.5	196.2	376.1	112.3	243.6	1385.5	2655.9
220	428	51%	81%	15.2	32.8	193.9	371.6	107.3	231.6	1369.2	2624.1
230	446	48%	80%	14.4	31.2	191.6	367.2	101.7	220.3	1353.0	2593.0
240	464	46%	79%	13.7	29.6	189.2	362.7	96.7	209.0	1336.1	2561.2
250	482	43%	78%	12.9	28	186.9	358.2	91.1	197.7	1319.8	2529.5
260	500	41%	77%	12.2	26.3	184.6	353.8	86.2	185.7	1303.6	2498.4

D Series Pump Materials of Construction

Part	Material
Body	Stainless Steel - ASTM A276-316 SS
	Hastelloy - C276
	Titanium - ASTM B348
Cavity Plate	Stainless Steel - ASTM A276-316 SS
	Hastelloy - C276
	Titanium - ASTM B348
Cap	Stainless Steel - ASTM A276-316 SS
	Hastelloy - C276
	Titanium - ASTM B348
Gears and Bearings	PPS (Polyphenylene Sulfide) - 30% Carbon / 15% PTFE
	PEEK (Polyetheretherketone) -15% Carbon
	PTFE
O-Rings	Viton
	PTFE
	Buna N
	EPR
Shaft	Stainless Steel - ASTM A276 - 316 SS
	Hastelloy - C276
	Titanium - ASTM B348
Magnet	Ceramic Encapsulated in PPS (Polyphenylene Sulfide)
	Ceramic Encapsulated in PEEK (Polyetheretherketone)
	Samarium Cobalt Encapsulated in PPS (Polyphenylene Sulfide)
	Samarium Cobalt Encapsulated in PEEK (Polyetheretherketone)
	Samarium Cobalt Weld Encapsulated and Molded Over with PPS (Polyphenylene Sulfide)
	Samarium Cobalt Weld Encapsulated and Molded Over with PEEK (Polyetheretherketone)
Magnet Cup	Stainless Steel - ASTM A 167
	Hastelloy - C276
	Titanium - ASTM B265
Magnet Shroud	Stainless Steel - AMS 5524
	Hastelloy - C276
	Titanium - ASTM B265

P Series Pump Materials of Construction

Part	Material
Body	PPS (Polyphenylene Sulfide) w/ 40% Glass
Cavity Plate	PPS (Polyphenylene Sulfide) PPS (Polyphenylene Sulfide) w/ 40% Glass
Cap	PPS (Polyphenylene Sulfide) w/ 40% Glass
Gears and Bearings	PPS (Polyphenylene Sulfide) - 30% Carbon / 15% PTFE
O-Rings	Viton
	EPR
Shaft	Stainless Steel - ASTM A276 - 316 SS
Magnet	Ceramic Encapsulated in PPS (Polyphenylene Sulfide)
Magnet Cup	Stainless Steel - ASTM A 167
Magnet Shroud	Stainless Steel - AMS 5524

T Series Pump Materials of Construction

Part	Material
Body	Stainless Steel - ASTM A276 - 316 SS
	Hastelloy - C276
	Titanium - ASTM B348
Cavity Plate	Stainless Steel - ASTM A276 - 316 SS
	Hastelloy - C276
	Titanium - ASTM B348
Cap	Stainless Steel - ASTM A276 - 316 SS
	Hastelloy - C276
	Titanium - ASTM B348
Gears And Bearings	PPS (Polyphenylene Sulfide) - 30% Carbon / 15% PTFE
	PEEK (Polyetheretherketone) - 15% Carbon
	PTFE
O-Rings	Viton
	Teflon (PTFE)
	Buna-N
	EPR
Shaft	Stainless Steel - ASTM A276 - 316 SS
	Hastelloy - C276
	Titanium - ASTM B348
Magnet	Ceramic Encapsulated in PPS (Polyphenylene Sulfide)
	Ceramic Encapsulated in PEEK (Polyetheretherketone)
	Samarium Cobalt Encapsulated in PPS (Polyphenylene Sulfide)
	Samarium Cobalt Encapsulated in PEEK (Polyetheretherketone)
	Samarium Cobalt Weld Encapsulated and Molded Over with PPS (Polyphenylene Sulfide)
	Samarium Cobalt Weld Encapsulated and Molded Over with PEEK (Polyetheretherketone)
Magnet Cup	Stainless Steel - ASTM A 167
	Hastelloy - C276
	Titanium - ASTM B265
Magnet Shroud	Stainless Steel - AMS 5524
	Hastelloy - C276
	Titanium - ASTM B265

D Series Pump NPIPr Data (PSIa)

Pump Size	Inlet Port Size	1000 rpm	2000 rpm	3000 rpm	4000 rpm	5000 rpm
.11	1/8 NPT	0.05	0.08	0.10	0.13	0.20
.19	1/8 NPT	0.10	0.13	0.26	0.32	0.53
.23	1/8 NPT	0.12	0.15	0.28	0.40	0.56
.38	1/8 NPT	0.18	0.25	0.43	0.90	1.10
.57	1/8 NPT	0.20	0.30	0.55	1.00	1.30
.68	1/8 NPT	0.25	0.35	0.60	1.10	1.54
.80	1/8 NPT	0.34	0.68	1.40	2.20	4.00
.11	1/4 NPT	0.03	0.06	0.10	0.13	0.19
.19	1/4 NPT	0.08	0.10	0.20	0.30	0.50
.23	1/4 NPT	0.09	0.11	0.24	0.33	0.55
.38	1/4 NPT	0.15	0.23	0.40	0.70	0.91
.57	1/4 NPT	0.18	0.28	0.50	0.80	1.10
.68	1/4 NPT	0.20	0.30	0.66	0.85	1.30
.80	1/4 NPT	0.25	0.35	0.70	1.00	1.80
.99	1/4 NPT	0.30	0.40	0.75	1.10	1.90
1.2	1/4 NPT	0.35	0.45	0.80	1.30	2.60
1.6	1/4 NPT	0.40	0.50	1.10	1.80	N/A
2.0	1/4 NPT	0.47	0.57	1.50	2.50	N/A
2.3	1/4 NPT	0.55	0.64	2.00	3.20	N/A

P Pump NPIPr Data (PSIa)

Pump Size	Inlet Port Size	1000 rpm	2000 rpm	3000 rpm	4000 rpm	5000 rpm
.38	1/8 NPT	0.18	0.25	0.43	0.90	1.10
.57	1/8 NPT	0.20	0.30	0.55	1.00	1.30
.68	1/8 NPT	0.25	0.35	0.60	1.10	1.54
.80	1/8 NPT	0.34	0.68	1.40	2.20	N/A

T Pump NPIPr Data (PSIa)

Pump Size	Inlet Port Size	1000 rpm	2000 rpm	3000 rpm	4000 rpm
2.6	3/8 NPT	0.50	1.50	3.10	5.60
5.3	3/8 NPT	0.53	1.60	3.40	5.90
7.9	3/8 NPT	1.00	1.90	3.80	6.10
8.0	3/4 NPT	1.00	1.90	3.80	6.10
12.	3/4 NPT	1.50	2.40	4.20	6.30

Note: D, P, & T are at 1 Cp Viscosity